

HARVIA TOP CLASS

HKSE500400

Harvia Topclass Combi is a unique combination of an electric heater and a steamer that provides sauna enjoyment for all senses. This heater is created for bathers who appreciate soft and humid steam and a fragrant atmosphere. The heater has luxurious soapstone cups to hold sauna fragrances and a stainless steel grate for bagged aromatic fragrances.



Features

Main material : Steel

H x W x D : 640.0 x 400.0 x 360.0 mm

Net weight (kg) : 16.3

Installation location : Wall

ID	GTIN	Output (kW)	Sauna room size min - max m3
HKSE500400	6417659005524	5 kW	3.0-6.0

Related products

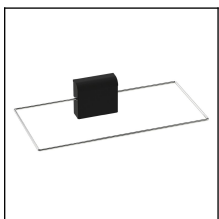

SFE-220400

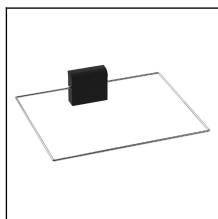

SFE-350400

Spare parts

Product	ID	Pcs
Silicon hose HGX 19/23	ZSTM-400	
Heating element 1500W/230V	ZSK-690	1
Heating element 2000W/230V	ZH-104	1
Soapstone cup Ø 46/36	ZH-205	2
Connection pipe 7/10, silicon	ZH-170	1
Pipe 7/10 1M, silicone transparent	SPZH-170	
Heating element 1500W 230V	SPZSK-690	
Heating element 2000W 230V	SPZH-104	
Soapstone cup Ø 46/36, grey	SPZH-205	

Technical details

Technical data	Type / attribute	HKSE500400
	Color	Stainless Steel
	Power output	5 kW
	Stone amount (kg)	20
Dimensions	Product width	400
	Product height	640
	Product depth (mm)	360
	Net weight (kg)	16.3
	Gross weight	17.6
	Package width	375
	Package height	690
	Package depth	415
Safety and installation dimensions	Safety distance front (non-combustible materials)	20
	Safety distance side (non-combustible materials)	35
	Safety distance behind (non-combustible materials)	35
	Safety distance (Ceiling)	1100
	Room min. height(depends on connections and therefore from output, star/delta)	1900

Technical images

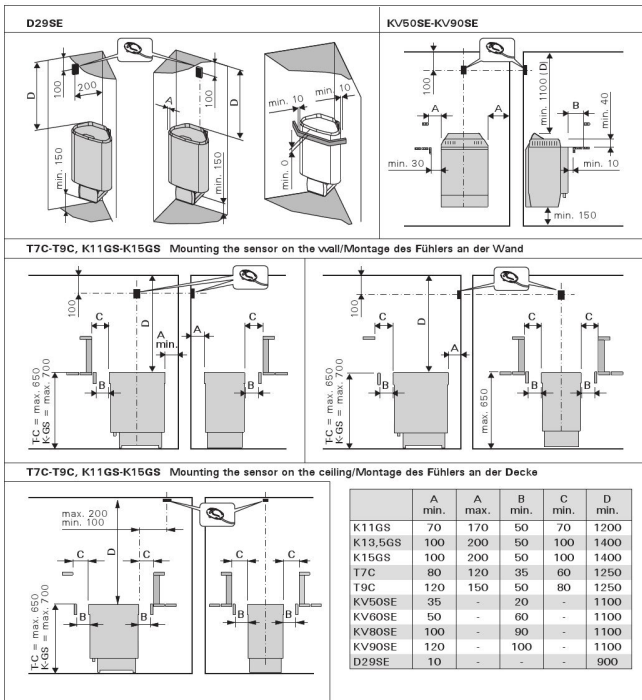

Safety distances (all dimensions in millimeters)